

SPECIFICATIONS/DATA

8" x 8" PC Style (Stackable) Assembly

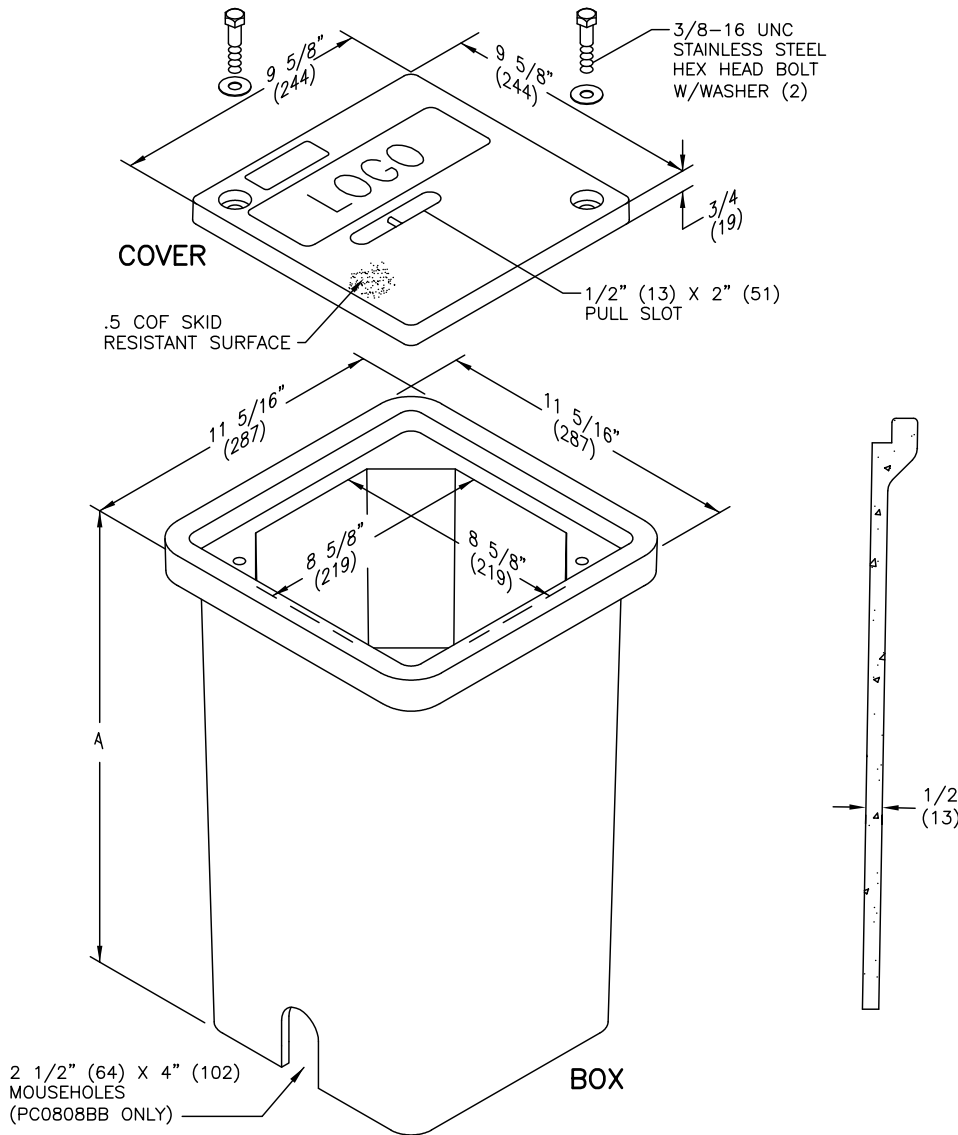

ENCLOSURE DRAWINGS

Covers (Blank unless logo is specified)

DESCRIPTION	PART NO.	WEIGHT #	DESIGN/TEST LOAD #	ANSI TIER*
W/2 Bolts	PC0808HA00	6 (3 kg)	15,000 / 22,500	15
	PC0808HG00	6 (3 kg)	15,000 / 22,500	15
	PC0808HH00	6 (3 kg)	22,500 / 33,750	22

Boxes (With self-aligning, replaceable EZ-Nut)

DESCRIPTION	PART NO.	WEIGHT #	DIMENSION A	DESIGN/TEST LOAD #	ANSI TIER*
Open Bottom	PC0808BA12	25 (11 kg)	12" (304 mm)	22,500 / 33,750	22
	PC0808BA18	36 (16 kg)	18" (457 mm)	22,500 / 33,750	22
Open Bottom w/2 Mouseholes	PC0808BB12	23 (10 kg)	12" (304 mm)	22,500 / 33,750	22
	PC0808BB18	34 (15 kg)	18" (457 mm)	22,500 / 33,750	22
Open Bottom w/Gasket	PC0808BG12	25 (11 kg)	12" (304 mm)	22,500 / 33,750	22
	PC0808BG18	34 (15 kg)	18" (457 mm)	22,500 / 33,750	22
Solid Bottom	PC0808DA18	42 (19 kg)	18 1/2" (470 mm)	22,500 / 33,750	22
Solid Bottom w/Gasket	PC0808DG18	42 (19 kg)	18 1/2" (470 mm)	22,500 / 33,750	22

Dimensions & weights in parentheses are metric equivalent.
For gasketed enclosure, see Options Section.

* Loadings comply with ANSI/SCTE 77 (see page 9).

