

SPECIFICATIONS/DATA

8" x 18" PC Style (Stackable) Assembly

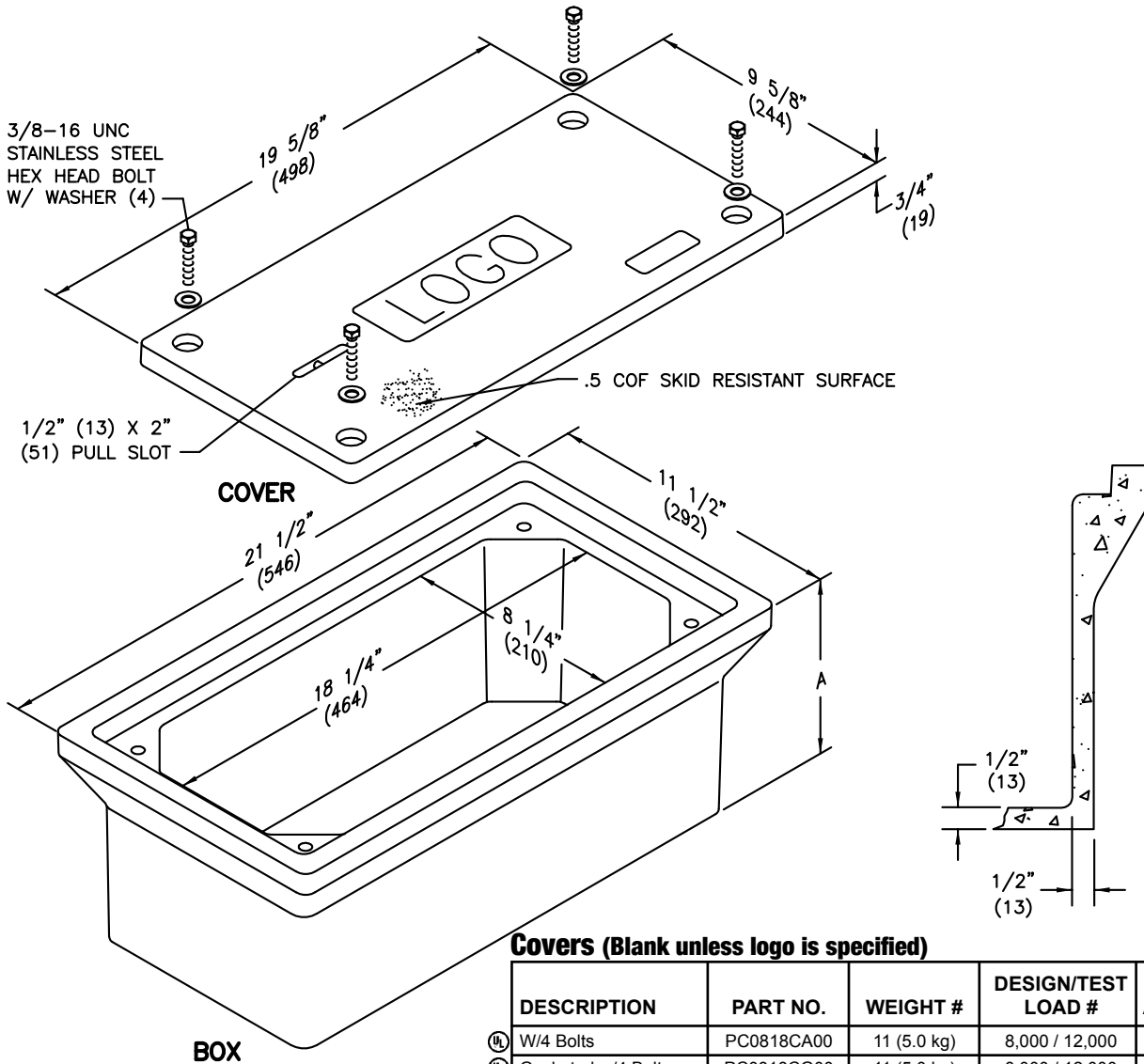

ENCLOSURE DRAWINGS

Covers (Blank unless logo is specified)

DESCRIPTION	PART NO.	WEIGHT #	DESIGN/TEST LOAD #	ANSI TIER*
Ⓛ W/4 Bolts	PC0818CA00	11 (5.0 kg)	8,000 / 12,000	8
Ⓛ Gasketed w/4 Bolts	PC0818CG00	11 (5.0 kg)	8,000 / 12,000	8
Ⓛ No Bolts	PC0818WA00	11 (5.0 kg)	8,000 / 12,000	8
Ⓛ Heavy Duty w/4 Bolts	PC0818HA00	11 (5.0 kg)	15,000 / 22,500	15
Ⓛ Gasketed Heavy Duty w/4 Bolts	PC0818HG00	11 (5.0 kg)	15,000 / 22,500	15

* Gasketed covers and bolt grommets must be used with a gasketed box. Gaskets reduce the inflow of fluids but do not make the enclosure water tight.

BOXES (Stackable with self-aligning, replaceable EZ-Nut)

DESCRIPTION	PART NO.	WEIGHT #	DIMENSION A	DESIGN/TEST LOAD #	ANSI TIER*
Ⓛ Open Bottom	PC0818BA07	25 (11 kg)	7" (178 mm)	15,000 / 22,500	15
	PC0818BA08	27 (12.2 kg)	8" (203 mm)	15,000 / 22,500	15
Ⓛ Open Bottom w/ Gasket	PC0818BG07	25 (11 kg)	7" (178 mm)	15,000 / 22,500	15
	PC0818BG08	27 (12.2 kg)	8" (203 mm)	15,000 / 22,500	15
Ⓛ Solid Bottom	PC0818DA07	32 (14.5 kg)	7 1/2" (191 mm)	15,000 / 22,500	15
	PC0818DA08	35 (15.9 kg)	8 1/2" (216 mm)	15,000 / 22,500	15
Ⓛ Solid Bottom w/ Gasket	PC0818DG07	32 (14.5 kg)	7 1/2" (191 mm)	15,000 / 22,500	15
	PC0818DG08	35 (15.9 kg)	8 1/2" (216 mm)	15,000 / 22,500	15

Dimensions & weights in parentheses are metric equivalent.

* Loadings comply with ANSI/SCTE 77 (see page 9).