

SPECIFICATIONS/DATA

11" x 18" PG Style (Stackable) Assembly

Covers (Blank unless logo is specified)

	DESCRIPTION	PART NO.	WEIGHT #	DESIGN/TEST LOAD #	ANSI TIER*
Ⓛ	W/2 Bolts	PG1118CA00	27 (12.2 kg)	8,000 / 12,000	8
Ⓛ	Gasketed w/2 Bolts	PG1118CG00	27 (12.2 kg)	8,000 / 12,000	8
Ⓛ	No Bolts	PG1118WA00	27 (12.2 kg)	8,000 / 12,000	8
Ⓛ	Heavy Duty w/2 Bolts	PG1118HA00	27 (12.2 kg)	15,000 / 22,500	15
Ⓛ	Gasketed Heavy Duty w/2 Bolts	PG1118HG00	27 (12.2 kg)	15,000 / 22,500	15
	Extra Heavy Duty w/2 Bolts	PG1118HH00	27 (12.2 kg)	22,500 / 33,750	22

- Covers with meter lids available upon request. See page 12 or page 56 for meter lid cover load rating explanation.
- Gasketed covers and bolt grommets must be used with a gasketed box. Gaskets reduce the inflow of fluids but do not make the enclosure water tight.

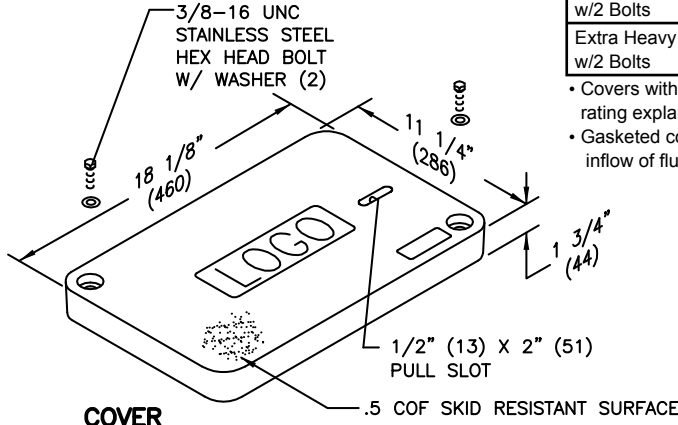

COVER

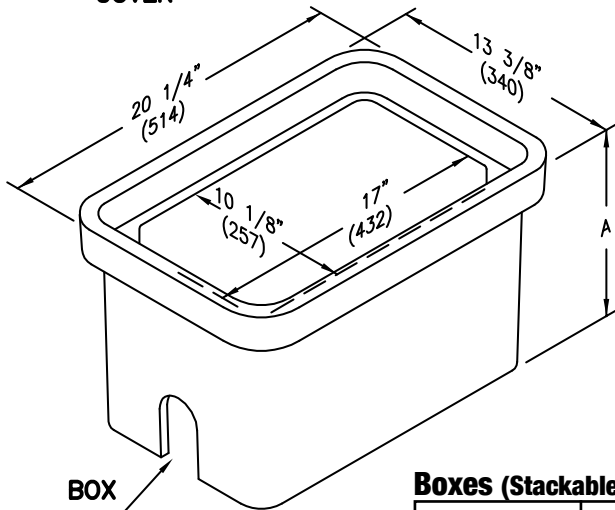

BOX

2X 2 1/2" (64) X 4" (102) MOUSEHOLES (PG1118BB only)

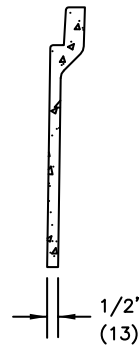

Boxes (Stackable with self-aligning, replaceable EZ-Nut)

	DESCRIPTION	PART NO.	WEIGHT #	DIMENSION A	DESIGN/TEST LOAD #	ANSI TIER*
Ⓛ	Open Bottom	PG1118BA12	40 (18 kg)	12" (305 mm)	22,500 / 33,750	22
		PG1118BA18	53 (24 kg)	18" (457 mm)	22,500 / 33,750	22
Ⓛ	Open Bottom w/ Gasket	PG1118BG12	40 (18 kg)	12" (305 mm)	22,500 / 33,750	22
		PG1118BG18	53 (24 kg)	18" (457 mm)	22,500 / 33,750	22
Ⓛ	Open Bottom w/ 2 Mouseholes	PG1118BB12	40 (18 kg)	12" (305 mm)	22,500 / 33,750	22
		PG1118BB18	53 (24 kg)	18" (457 mm)	22,500 / 33,750	22
Ⓛ	Solid Bottom	PG1118DA12	43 (19.5 kg)	12 1/2" (318 mm)	22,500 / 33,750	22
		PG1118DA18	60 (27 kg)	18 1/2" (470 mm)	22,500 / 33,750	22
Ⓛ	Solid Bottom w/ Gasket	PG1118DG12	43 (19.5 kg)	12 1/2" (318 mm)	22,500 / 33,750	22
		PG1118DG18	60 (27 kg)	18 1/2" (470 mm)	22,500 / 33,750	22
Ⓛ	Footed Box	PG1118JA12	41 (19 kg)	12 1/2" (318 mm)	22,500 / 33,750	22
		PG1118JA18	55 (25 kg)	18 1/2" (470 mm)	22,500 / 33,750	22

Dimensions & weights in parentheses are metric equivalent.
* Loadings comply with ANSI/SCTE 77 (see page 9).

ENCLOSURE DRAWINGS