

SPECIFICATIONS/DATA

48" x 96" PG Style (Stackable) Assembly

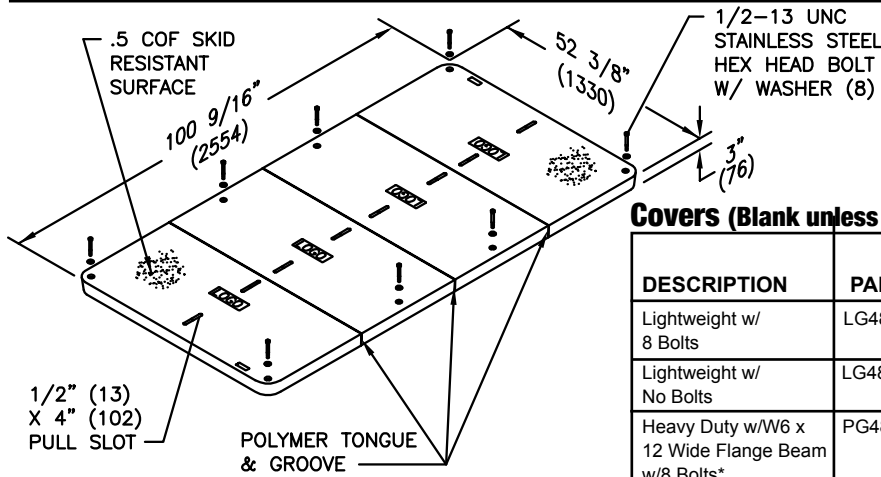

Covers (Blank unless logo is specified)

DESCRIPTION	PART NO.	WEIGHT #	DESIGN/TEST LOAD #	ANSI TIER*
Lightweight w/ 8 Bolts	LG4896CA00	608 (276.0 kg)	5,000 / 7,500	5
Lightweight w/ No Bolts	LG4896WA00	608 (276.0 kg)	5,000 / 7,500	5
Heavy Duty w/W6 x 12 Wide Flange Beam w/8 Bolts*	PG4896HA00	794 (360.0 kg)	15,000 / 22,500	15
Extra Heavy Duty w/ 6 x 4 Tubing w/8 Bolts*	PG4896HH00	1186 (538.0 kg)	22,500 / 33,750	22

* Total weight for 48" x 96" HA beam is 153 lbs (69 kg). Total weight for 48" x 96" HH tubing is 285 lbs (129 kg).

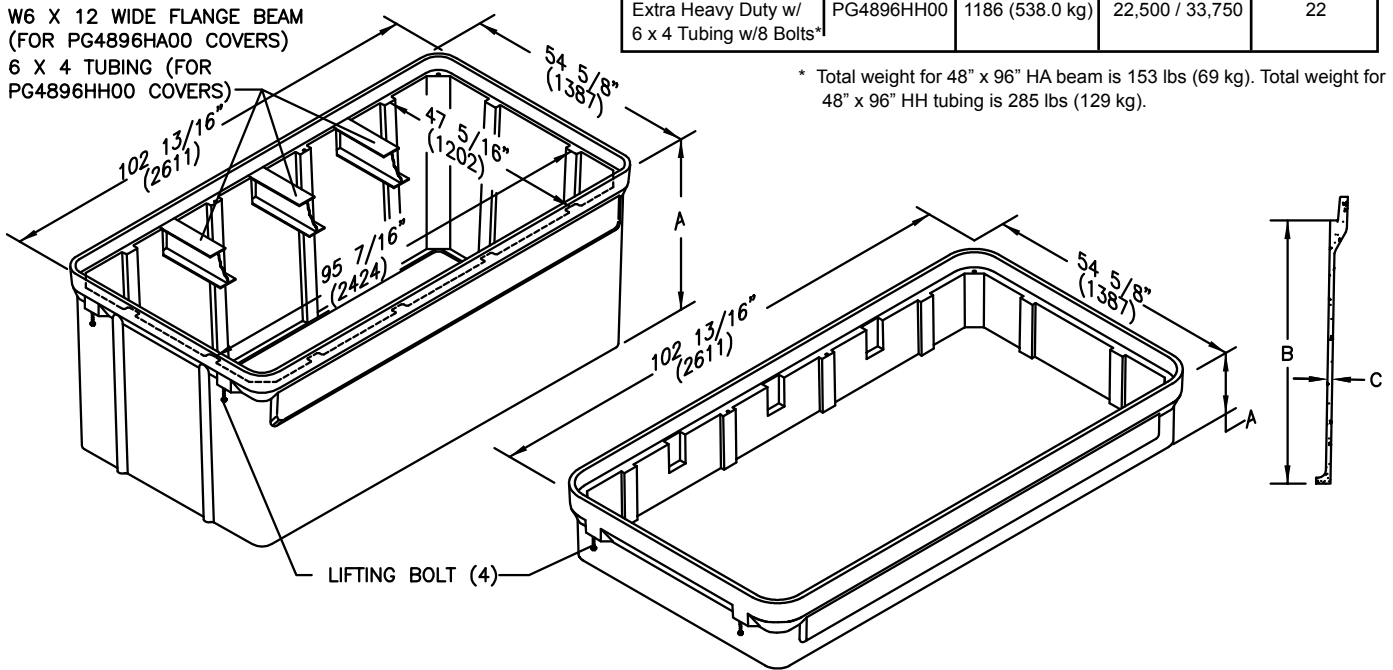

ENCLOSURE DRAWINGS

Boxes (Stackable with self-aligning, replaceable EZ-Nut)

DESCRIPTION	PART NO.	WEIGHT #	DIMENSION A	DIMENSION B	DIMENSION C	DESIGN/TEST LOAD #	ANSI TIER*
Open Bottom	PG4896BA48	1384 (628 kg)	49 3/4" (1264 mm)	45" (1143 mm)	5/8" (16 mm)	22,500 / 33,750	22
Solid Bottom	PG4896DA48	1537 (697 kg)	48 3/4" (1238 mm)	45" (1143 mm)	5/8" (16 mm)	22,500 / 33,750	22

Extension (Stackable with self-aligning, replaceable EZ-Nut; for use on top of box only)

Top extensions are available to give extra depth.

DESCRIPTION	PART NO.	WEIGHT #	DIMENSION A	DIMENSION B	DIMENSION C	DESIGN/TEST LOAD #	ANSI TIER*
Open Bottom, Beam Pocket, No Beam Provided	PG4896EA12	485 (220.0 kg)	15" (381 mm)	12" (305 mm)	1 1/16" (27 mm)	22,500 / 33,750	22

Dimensions & weights in parentheses are metric equivalent.

* Loadings comply with ANSI/SCTE 77 (see page 9).

